

**CHECKING THE SWITCH**

**CHECKING THE SWITCH**

Use a pocket tester to check the terminals for continuity. If the continuity is faulty at any point, replace the switch.



**Pocket tester:**  
P/N. YU-03112, 90890-03112

**NOTE:**

- Set the pocket tester to “0” before starting the test.
- The pocket tester should be set to the “Ω × 1” range when testing the switch for continuity.
- Turn the switch on and off a few times when checking it.

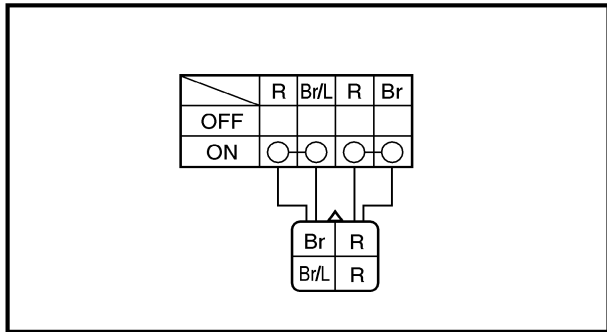

**CHECKING A SWITCH SHOWN IN THE MANUAL**

The terminal connections for switches (main switch, handlebar switch, engine stop switch, light switch, etc.) are shown in a chart similar to the one on the left.

This chart shows the switch positions in the column and the switch lead colors in the top row.

For each switch position, “○—○” indicates the terminals with continuity.

**The example chart shows that:**

There is continuity between red and brown/blue, and between red and brown when the switch is set to “ON”.



## CHECKING THE SWITCH CONTINUITY

Refer to "CHECKING THE SWITCH" and check for continuity between lead terminals.

Poor connection, no continuity → Correct or replace.

\* The coupler locations are circled.

